

Ventilation Equipment

304 S/S Wall Hood+Double Filters 1200X1400mm

ITEM # _____

MODEL # _____

NAME # _____

SIS # _____

AIA # _____



640270 (VAP1214)

304 stainless steel Wall Hood with double filters

Short Form Specification

Item No. _____

Constructed in 304 AISI stainless steel. Continuously welded joints. Equipped with labyrinth filters (positioned on front) in 304 AISI stainless steel, blind panels in 304 AISI stainless steel, grease collecting trough all around and condensate drain sleeve.

The rear baffle directs the fumes towards the filter surface, condensing the steam which is then conveyed through the outer ducting into the discharge. Suitable for use where large volumes of steam must be exhausted (i.e. ovens, dishwashers, pan washers, etc.)

Main Features

- Low noise level.
- External panels with upturned edges to avoid injuries.
- Prearranged for installation of lighting.
- Perimetral welded gutter with condensate drain (diam.= 3/8").

Construction

- Eyebolts and screw anchors for ceiling installation.
- Internal baffle to facilitate steam condensation and collection.
- Entirely constructed in 304 AISI stainless steel.
- Labyrinth filters guarantee constant filtration to avoid clogging and to protect against fire.
- 304 AISI stainless steel blind panels for a correct exhaustion.
- Outlet holes are sized in order to minimize drops in pressure.
- 304 AISI stainless steel labyrinth filters easily removable for cleaning.

Included Accessories

- 3 of 304 Stainless steel labyrinth filter (h=350 mm) PNC 640050

Optional Accessories

- Neon light for hoods 650mm PNC 644833
- LED light for hoods 650mm PNC 644835

APPROVAL: _____



Electrolux
PROFESSIONAL

Ventilation Equipment 304 S/S Wall Hood+Double Filters 1200X1400mm

Front

cod. 640270

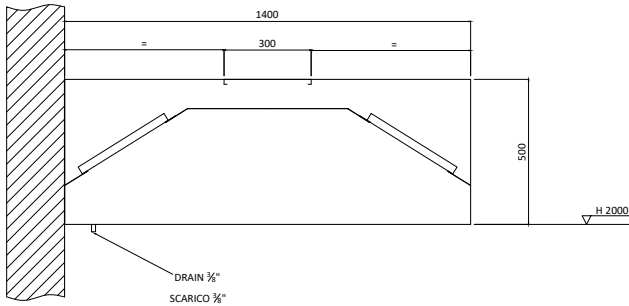

Side

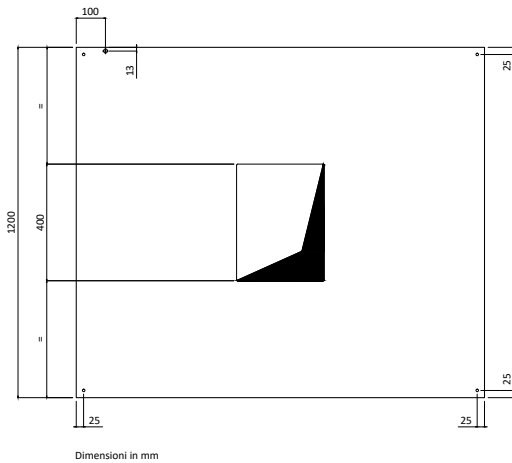

Key Information:

External dimensions, Width:

640270 (VAP1214) 1200 mm

External dimensions, Depth: 1400 mm

External dimensions, Height: 500 mm

Net weight: 56 kg

Air Emission:

Air capacity: 1800 mc/h



Ventilation Equipment
304 S/S Wall Hood+Double Filters 1200X1400mm

The company reserves the right to make modifications to the products
without prior notice. All information correct at time of printing.

2024.09.01